

Set of 4 Extended Pegs



Description

These pegs attach to the upper and lower fixing tables to keep samples secure during torque testing. The extended length pegs are to keep taller samples vertically aligned.

Applications

Used for closure torque testing of:

- Bottles
- Jars

Specifications

Part No.	Thread 1	Diameter Ø		Length	
432-447	M6	16 mm	0.63"	35 mm	1.38"
432-250	M6	16 mm	0.63"	100 mm	3.94"

Dimensions mm (inch)

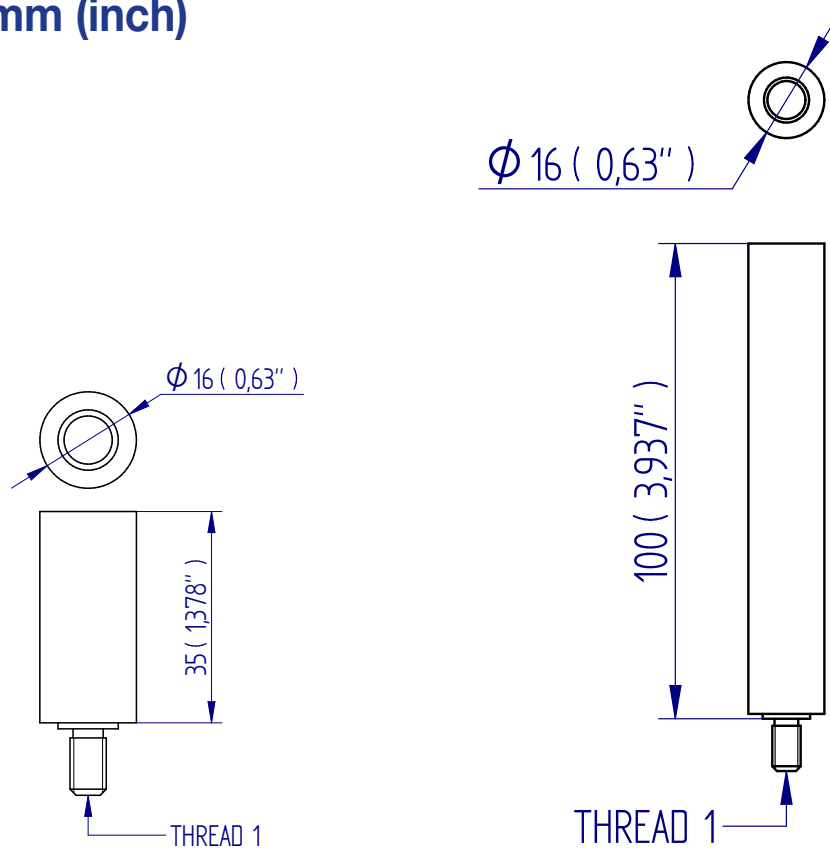

432-447

432-250



FS 58553

003

DISTRIBUTOR STAMP

DS-1134-01

Mecmesin reserves the right to alter equipment specifications without prior notice. E&OE

Head Office
Mecmesin Limited

w: www.mecmesin.com
e: sales@mecmesin.com

North America
Mecmesin Corporation

w: www.mecmesincorp.com
e: info@mecmesincorp.com

France
Mecmesin France

w: www.mecmesin.fr
e: contact@mecmesin.fr

Asia
Mecmesin Asia Co., Ltd

w: www.mecmesinasia.com
e: sales@mecmesinasia.com

Germany
Mecmesin GmbH

w: www.mecmesin.de
e: info@mecmesin.de

China
Mecmesin (Shanghai) Pte Ltd

w: www.mecmesin.cn
e: sales@mecmesin.cn