

Container Holder (4-peg adjustable)

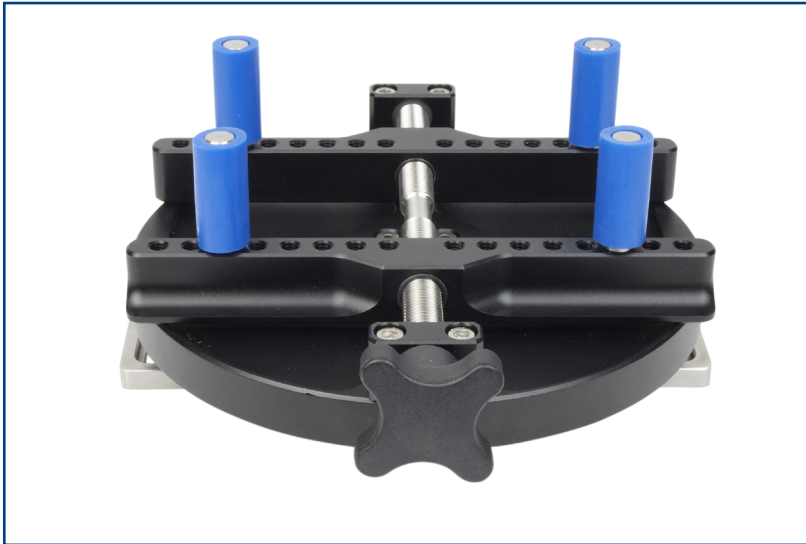

▲ Large container holder

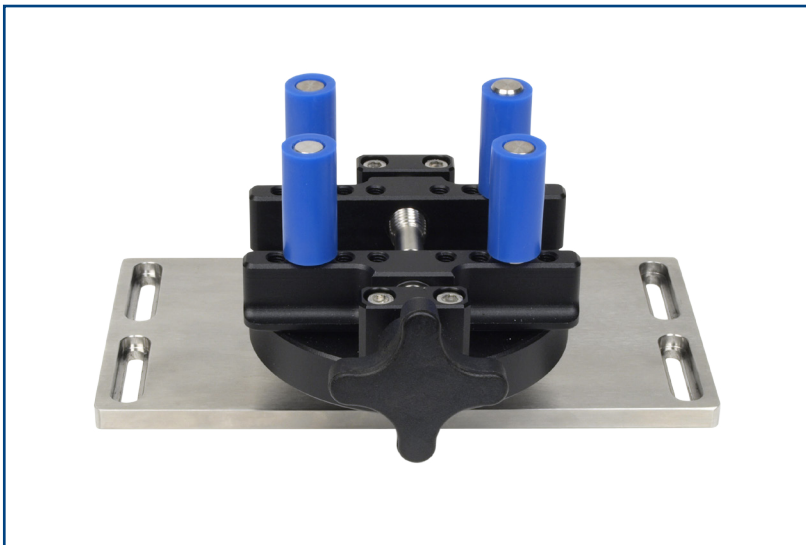

▲ Small container holder



Description

The 4-peg container holder is designed to securely hold different shapes and sizes of containers during tensile testing (e.g. sports caps or flipcaps). Available in two ranges of adjustability.

Use with crosshead extension 432-508.

Applications

- pull-off closures

Specification

Part No.	Load Capacity			Thread 1	Container Min./Max. Ø		Height (c)	
432-411	100 N	10 kgf	22 lbf	4 x M5	10 mm / 190 mm	0.39" / 7.48"	102 mm	4.00"
432-493	100 N	10 kgf	22 lbf	4 x M5	10 mm / 78 mm	0.39" / 3.07"	103 mm	4.04"

Dimensions mm (inch)

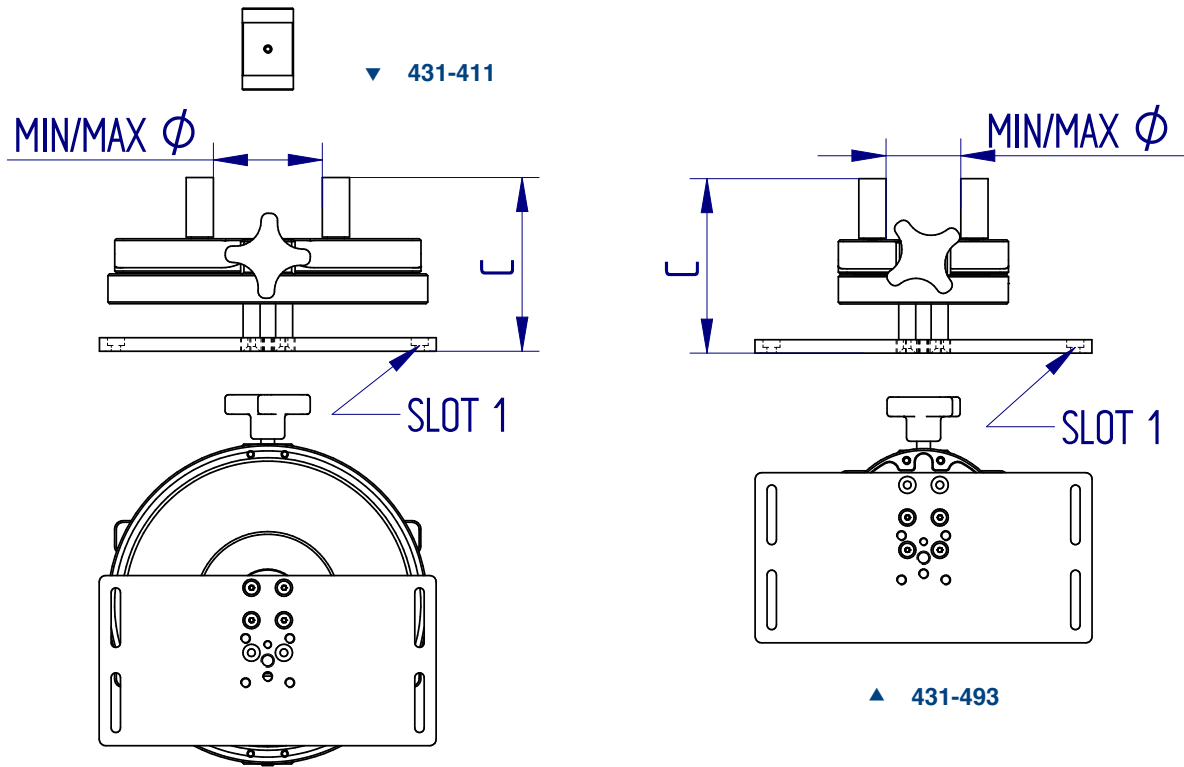

DISTRIBUTOR STAMP

Mecmesin reserves the right to alter equipment specifications without prior notice.

E&OE



FS 58553

Head Office - UK
Mecmesin Limited

w: www.mecmesin.com
e: sales@mecmesin.com

North America
Mecmesin Corporation

w: www.mecmesincorp.com
e: info@mecmesincorp.com

France
Mecmesin France

w: www.mecmesin.fr
e: contact@mecmesin.fr

Asia
Mecmesin Asia Co., Ltd

w: www.mecmesinasia.com
e: sales@mecmesinasia.com

Germany
Mecmesin GmbH

w: www.mecmesin.de
e: info@mecmesin.de

China
Mecmesin (Shanghai) Pte Ltd

w: www.mecmesin.cn
e: sales@mecmesin.cn